RESEARCH METHODOLOGY OF CUTTING PROCESSES OF ASPEN WOOD**Andis Ābele, Henn Tuherm**

Latvia University of Agriculture

Andis.Abele@llu.lv

Abstract

Machining of wood of soft deciduous trees is currently based on the knowledge about cutting of wood of hard deciduous and coniferous trees and has not developed a comprehensive research methodology of cutting processes. Therefore, the objective of the study is a development of methodology for longitudinal sawing with circular saw and straight milling that would be utilized with a purpose of acquiring further knowledge on wood cutting and the improvement of cutting tool designs. Sub-objective of the study is determination of duration of cutter's wear periods when using developed methodology. For the purpose of solving problems regarding cutting process of soft deciduous wood, the optimization of cutting tools and cutting modes were carried out in conditions that comply with the tendencies of the practise. The cutting process was carried out by a computer numerical control machine and the data acquisition by electronic measuring instruments. Aspen (*Populus tremula* L.) wood was used for wood samples. The methodology was developed for sawing, which complements the authors previously described methodology of the milling process investigations. Initially, only the results of periods of cutter wear and cutting velocity effects on these periods when milling process is used were obtained. It was concluded that the methodology can be used for further investigations and the critical wear period begins two times later when cutting velocity increases twice.

Key words: sawing, milling, aspen, methodology of cutting processes, optimization of wood cutting.

Introduction

Wood processing industry is more and more beginning to focus on processing wood of soft deciduous trees, such as aspen, manufacturing not only decoration boards, but also structural building elements and furniture. Considering the volume of the soft deciduous wood resources that are available and its regeneration potential, the use of these particular tree species in manufacturing wood products gives essential privileges. It reduces the mass of products and its production costs comparing to a denser wood species. Sawing and milling are two of the major mechanical wood processing techniques that are applied during the technological process of manufacturing products from any type of wood. Furthermore, from all the wood cutting processes that are based on sawing, the most popular is longitudinal cutting with circular saws. The straight milling, however, is most popular from all the milling techniques. This also means that the majority of studies regarding wood cutting processes are interrelated with these techniques of mechanical wood processing. Studies that aim to determine the right cutting modes for deal cutting and other processes are mostly carried out by processing wood of conifers or hard deciduous trees (Budakçı et al., 2011; Fotin et al., 2010; Nordström and Bergström, 2001; Simonin et al., 2009). It may be attributed to the fact that the wood of soft deciduous trees originally was considered inferior and not suitable for mechanical processing, and because of that an insufficient amount of studies has been carried out regarding this type of wood both in Latvia and abroad. Therefore, the current regularities of processing the soft deciduous wood are based on regularities that have been learned during the cutting processes of wood of coniferous and hard deciduous

trees. It is because the knowledge on the regularities regarding longitudinal sawing and straight milling of soft deciduous wood is not sufficient enough to choose the cutting tools and cutting modes that would be the most appropriate for this type of wood. This creates a necessity to develop an optimal cutting tool and cutting modes prescribed exactly for the processes of cutting soft deciduous wood, as it is anticipated that the use of these species of wood will only be increasing.

A wide range of studies regarding the wood cutting process that have provided valuable long-term results, have been carried out in a number of countries, whereas only few notable studies have been carried out in the Republic of Latvia. One of them was developed during the 1970s, explaining the resistance to abrasion of cemented-carbide compositions during the process of cutting pressed birch and gray alder wood (Sleņģis et al., 2009). Another notable study that has to be mentioned is the one regarding cutting process of black alder and aspen, carried out by the Department of Wood Processing at Latvia University of Agriculture in 2008, within the framework of the State Research programme (Sleņģis et al., 2009). Changes in roughness of the surface and cutting power were determined for these types of wood by processing samples of them in different cutting velocities and feed speeds whereas changes in abrasion of cutting tool, depending on its angular parameters during the process of cutting aspen wood were described in the studies that were carried out from 2010 to 2012 (Ābele and Miončinskis, 2012). However, the studies carried out in both the Republic of Latvia and abroad regarding wood cutting process do not provide comprehensive information regarding

what impact various factors have on the process of cutting soft deciduous wood, taking into consideration the impact of both desirable and undesirable features of the respective cutting mode.

New designs of circular saws and milling cutters that would reduce or even eliminate the unwanted features of the mutual impact between wood and cutting tool would also reduce the production costs, extending the permissible operating period and increasing performance of the cutting tool. In addition to that, by reducing the kerf width, while maintaining stability of the circular saw, an opportunity to use the wood and energy resources more efficiently is given. Propositions of new circular saw and milling cutter designs could make a practical contribution not only to improvement of cutting modes and cutting tools for soft deciduous, but coniferous and hard deciduous wood as well.

The optimization of cutting modes also provides a theoretical contribution to solutions regarding wood cutting process, improving the already existing knowledge on the features of the mutual impact between wood and cutting tools, which could serve as a base for development of methodology for an analytic description of cutting process. The currently available information is not always sufficient enough, especially when processing soft deciduous wood, to develop a comprehensive theoretical structure of the cutting process. Furthermore, the traditional calculation does not take into consideration the cases, when circular saws with hard tipped teeth are used, adding that the aforesaid method is the most common nowadays for producing teeth of a saw. Ascertaining that this feature actually impacts the cutting process more comprehensive and state of the art analytic methods might be provided.

Solving complications regarding the study, it is necessary to initially determine what factors are involved in the cutting process, and which ones impact the undesirable features of the process most. Only then it is possible to develop propositions and create new cutting tool designs that would reduce the aforesaid undesirable features, providing the optimal conditions exactly for the cutting process of soft deciduous wood.

Therefore, the objective of the study is a development of methodology for longitudinal sawing and straight milling processes. That would be appropriate for further knowledge obtaining about interaction between wood and cutting tool, and for the improvement of cutting tool designs exactly for wood of soft deciduous trees. Second line objective of the study is determination of duration of cutter's wear periods when using developed methodology.

Materials and Methods

The cutting processes of circular saw and milling cutter are similar in respect to both kinematics of the cutting tools and features of the chips formation. The main difference between the two is the purpose of the cutting process. For a circular saw it is dividing wood in smaller pieces, while in straight milling it is surface levelling and roughness reduction. Therefore, the methodology of wood cutting process in relation to sawing is mainly described. Methodology of straight milling process is described in other paper of authors (Ābele and Miončinskis, 2012).

Wood cutting process is mechanized and often even automatical in most of the modern wood cutting companies. Therefore, the experiments of the wood cutting study shall be performed by using computer numerical control (CNC) machines, so a cutting process that complies with state of the art tendencies of wood cutting industry could be ensured. A multifunctional CNC machine 'Biese Rover 325', which can be set up either as a circular saw or milling cutter, has been used in this study.

A unique circular saw tipped by tungsten carbide compositions has been designed for the experimental work. It is the most common method for producing saw teeth as it improves the abrasion resistance of the saw teeth (Simonin et al., 2009). The circular saw has been produced by a cutting tool producer from Latvia – 'Nook Ltd.'. The parameters of the circular saw are indicated in Figure 1. This circular saw consists only of a two teeth that are located on the opposite circumference points of the circular saw. Therefore, it takes less time to reach the prescribed load capacity for the saw teeth comparing to standard circular saws. This is characterized by an efficient cutting distance per tooth, which is probably the most important parameter to reach a level of wear for the saw teeth that would comply with the practice conditions (Nordström, 2005). In respect to that, the length of the cutting trajectory for a single tooth is 10,000 m. Respectively, this means that the cutting distance in this study, which is equivalent to the practice conditions, should be approximately 20,000 m, knowing that the saw has two teeth.

Samples of aspen wood with a moisture content of 8...10% have been used during the experiment work of the study. For the purpose of maintaining the stiffness and resistance of the processed wood samples during the cutting process, sawing has been carried out by creating longitudinal kerfs next to each other on both wider sides of the wood sample, leaving 3 mm wide partition between the kerfs. The scheme of kerfs is illustrated in Figure 2. Taking into consideration that the distance from cutting circumference of the circular saw to the outer circumference of the pressure disc is

30 mm, height of the kerf is set to 28 mm. Therefore, an enclosed cutting process has been ensured for every kerf, which is a normal characteristic of sawing. The depth that has been set for the kerf gives a 61.5 mm long length of the cutting trajectory for every rotation of the spindle. For the length of cutting trajectory at one rotation of the spindle calculating the following equation (1) can be used:

$$l = u_z + \frac{\pi \cdot D}{360} \arccos\left(1 - \frac{2 \cdot H}{D}\right), \quad (1)$$

where l is length of cutting trajectory at one rotation of the spindle, mm; u_z is feed per tooth, mm; π is the constant ($\pi = 3.14$); D is diameter of cutting circumference, mm; H is height of the kerf (using technique of sawing) or thickness of cutting layer (using technique of milling), mm.

The optimal cutting velocity for a circular saw is 50 m s^{-1} but the feed per tooth is 1 mm (Nordström and Bergström, 2001). Therefore, the feed speed during the experiments shall be 16 m min^{-1} , which complies with normal cutting conditions in practice. For the feed speed calculating the following equation (2) can be used:

$$u = \frac{u_z \cdot n \cdot z}{1000}, \quad (2)$$

where u is feed speed, m min^{-1} ; u_z is feed per tooth, mm; n is rotation frequency of shaft (dependent on cutting velocity), min^{-1} ; z is number of teeth of cutting tool.

To determine the optimal cutting modes, one should not only be using the parameters that are considered to be optimal as of right now. Therefore, they shall only be used during the initial experiments;

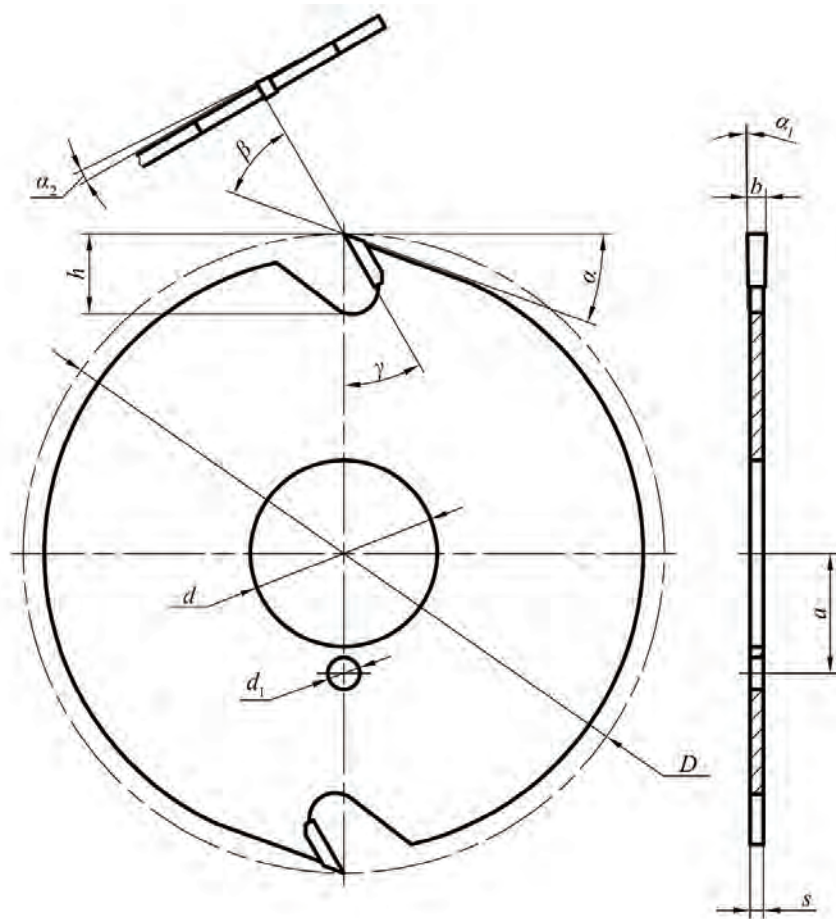

Figure 1. The parameters of the circular saw.

- D - diameter of cutting circumference ($D = 120 \text{ mm}$);
- d - diameter of basing bore ($d = 35 \text{ mm}$);
- d_1 - diameter of pin bore ($d_1 = 6 \text{ mm}$);
- a - length between centres of bores ($a = 22.9 \text{ mm}$);
- s - saw body thickness ($s = 2 \text{ mm}$);
- b - kerf width ($b = 3 \text{ mm}$);
- h - tooth height ($h = 15 \text{ mm}$);
- α - clearance angle ($\alpha = 20^\circ$);
- β - sharpness angle ($\beta = 40^\circ$);
- γ - rake angle ($\gamma = 30^\circ$);
- α_1 - radial clearance angle ($\alpha_1 = 2^\circ$);
- α_2 - tangential clearance angle ($\alpha_2 = 3^\circ$).

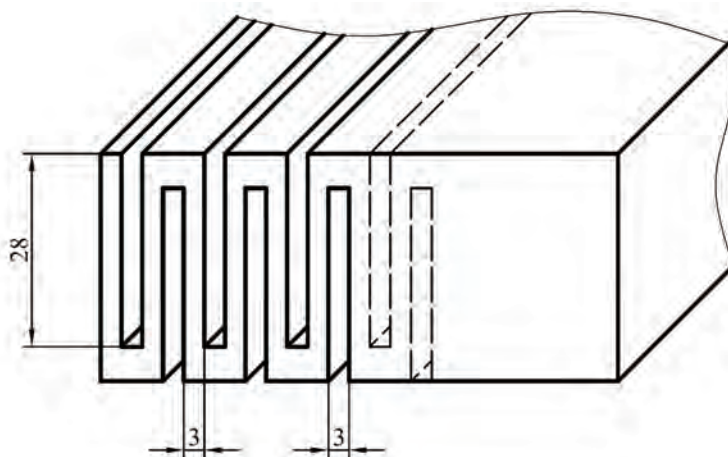

Figure 2. The scheme of kerfs.

however, it is necessary to alternate the parameters as the experimental work continues, including the values of cutting velocity and feed per tooth, which are respectively larger and smaller than $50 \text{ m}\cdot\text{s}^{-1}$ and 1 mm.

Electronic measuring instruments have been used in determination of the results, increasing the accuracy of the experiments. Roughness of the surface has been determined every time when a prescribed length of the cutting trajectory has been reached. To determine the right time for performing these measurements, the calculation of the breakdown of cutting trajectory has been used, previously described in other paper (Ābele and Miončinskis, 2012). A device ‘Perthometer M2’ by company ‘Mahr’ has been used for measuring the roughness of the processed wood surface. The device is applicable only for measuring roughness of a flat surface; therefore, the wood sample after sawing was cut completely to open up the inner surface of the kerfs, from which taking a roughness measurement was anticipated. This device ensures determination of four parameters that characterize roughness:

- R_a – the deviation of the arithmetical mean of the surface profile roughness from the mean of the depth of the surface profile roughness;
- R_z – the mean distance between the five highest and five lowest points of the surface profile;
- R_{\max} – the maximum roughness depth of the surface profile;
- R_k – the median value of the cumulative breakdown of the surface profile roughness values (Flitney, 2007).

The cutting force and power may be determined by applying various methods. Most commonly used methods are based on the electricity consumed by the engine of the cutting tool. One of such methods is determination of changes in the electrical current that has been consumed by an electrical engine (Barcik

et al., 2010). The other method though compares the power of the electrical engine before and during the cutting process, resulting in a difference that indicates the power that has been consumed (Ābele and Miončinskis, 2012). However, only electrical power can be determined by using these two above mentioned methods, thus, they do not provide direct and accurate results, knowing that the cutting process is characterized the best by the mechanical power. Therefore, a method of measuring the torque of the cutting tool’s spindle has been used in this study. For this matter a measuring device that performs a constant monitoring of changes in the torque throughout the cutting process has been used. To calculate the cutting power (3) and cutting force (4), using the data from the torque measurements (Kováč and Mikleš, 2010), the following equation can be used:

$$N_{gr} = \frac{2 \cdot 1000 \cdot M \cdot v}{D}, \quad (3)$$

$$P_{gr} = \frac{N_{gr}}{v}, \quad (4)$$

where N_{gr} is cutting power, W; M is torque of shaft, N m; v is cutting velocity, $\text{m}\cdot\text{s}^{-1}$; D is diameter of cutting circumference, mm; P_{gr} is cutting force, N.

Rounding radius of the cutters has been determined by using the replicating method. At first, every time after a prescribed length of the cutting trajectory was reached (the same as used for measuring the roughness), a lead plate was pressed on the cutting edge of the cutter perpendicularly. Then this imprint was analyzed with a microscope, measuring the rounding radius of the cutting edge. Lead is a relatively soft substance, which easily may be deformed. Therefore, a set of three lead plates shall be used in making of the imprinting; however, only one, the middle one, shall

be used for the examination of the imprint. A digital microscope ‘Keyence VHX-100 K’, with up to 800 times optical magnification was used for the purpose of examining the imprint.

During the initial stage of the study regarding cutting modes of the soft deciduous wood, cutting tools shall be used with the angular and linear parameters, as well as the body structure close to the indications that have been used in common practice of wood cutting. It is essential in learning about the current situation of the wood cutting modes, meaning what the main factors are, and what impacts them most. By discovering the most significant factors that impact the cutting modes adversely, it is possible to find solutions to eliminate or at least reduce them. For this matter, propositions regarding the improvements of the cutting tool designs may be developed based on the discovered adverse features that are impacting the cutting process. Then, after the improved models of the cutting tools have been developed, the wood cutting experiments may be carried out, examining the effectiveness of the implemented improvements, and their impact on the cutting mode. Essentially, it is impossible to limit all the adverse features of the cutting process at once; therefore, the optimization of the cutting tool design and cutting modes shall be carried out gradually. Simultaneously with the examination of the technological indications of the improvements, it is necessary to carry out a cost-effectiveness analysis, determining whether the implementation of the new improved cutting tool, and, respectively, the replacement of the former one, is comprehensively beneficial in the wood processing.

Changes in the parameters of wood cutting modes are quantifiable in respect to the time and the length of

the cutting trajectory (Ābele and Miončinskis, 2012; Fotin et al., 2009). Therefore, for the mathematical calculations and analysis, it is preferable to use correlation and regression analyses that also indicate the regularities among the changes of the cutting mode parameters.

Results and Discussion

The characteristic curve regarding the changes of the surface roughness from the processed wood (Figure 3) is visually similar to the one that has been discovered during the previous studies regarding the cutting process of the soft deciduous wood (Ābele, 2010). From obtained results (Figure 3) it can be concluded that initial wear period is in a range of cutting trajectory from 0 m to 8,000 m, which complies with cutting time 1.5 hours. Afterwards, the intensity of processed wooden surface roughness decreases. It shows the beginning of monotone wear period of cutter, which continuous up to reaching 95,000 m length of cutting trajectory with corresponding cutting time 16 hours. This cutter’s wear period differs from reference data (Astakhov and Davim, 2008) with that there is not a gradual increase in surface roughness, but it almost does not change in the whole wear period. After a monotone cutter’s wear period ends, the surface roughness R_a sharply increases again, showing the beginning of critical wear period of cutter. It means that in this case re-sharpening of the cutter should be organized after work of 16 hours.

Even though the tendency towards changes in the surface roughness in respect to the length of the cutting trajectory is very alike, when comparing this characteristic curve with previously obtained, the length of the cutting trajectory after which the

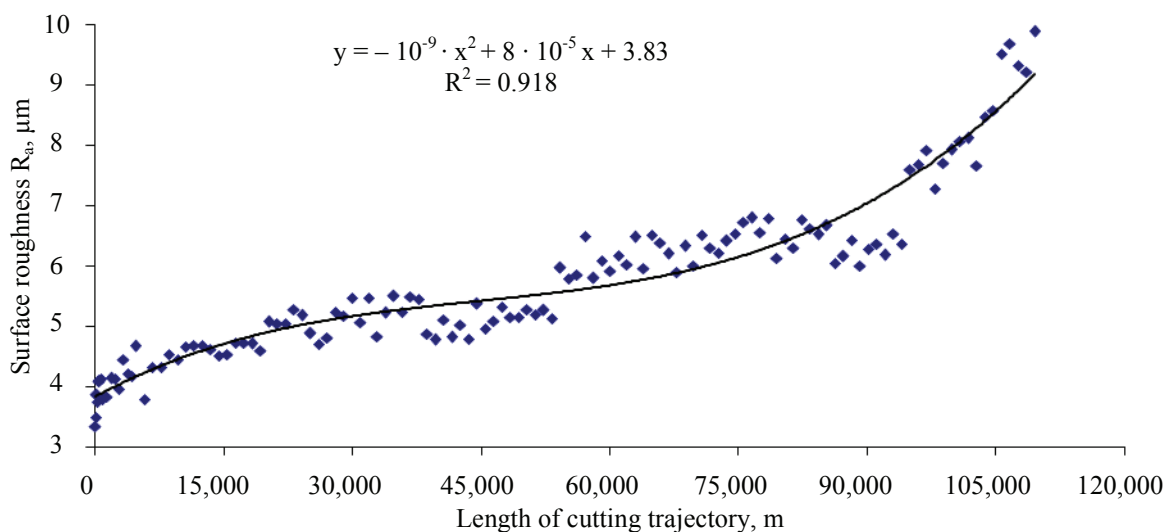

Figure 3. Changes of surface roughness R_a respect to length of cutting trajectory when milling at rake angle of 10° .

monotone and critical stage of wear initiates is different. The beginning values of the monotone wear stage differ only by 3,000 m; however, the beginning values of the critical wear stage differ almost twice, which is a very significant variance. Such contrasting results of the experiment may be explained by the difference in some specific mode parameters, such as the cutting velocity and feed speed.

The cutting velocity and feed speed values used in the 2010 study were 20.4 m s^{-1} and 2.4 m min^{-1} respectively (Ābele, 2010). However, in this study the cutting speed has been increased up to 40 m s^{-1} for a purpose of bringing it nearer to the optimal cutting velocity that is being used in straight milling machines, and feed speed increased to 4.7 m min^{-1} (according to Ābele and Miončinskis, 2012). That resulted in an unaffected value of feed per tooth (0.443 mm). The main parameter that should be taken into consideration as a result changing factor is the cutting velocity because it is impacting the wear of the cutter most (Astakov and Davim, 2008). The feed speed in this case is not as important because the feed per tooth has remained unchanged throughout both studies. Therefore, it may be assumed that when the cutting velocity has been increased from 20.4 to 40 m s^{-1} , it takes twice longer cutting trajectory to initiate the critical stage of wear for the cutter. However, it has also been ascertained by other authors that by increasing the cutting velocity, the critical wear phase of the cutter is reached sooner (Banshoya et al., 1998; Ratnasingam and Perkins, 1998). The contrasting results may be explained by the fact that the wear of the cutter in various cutting velocities has always been expressed in respect to the cutting time by other authors. Though, the feed speed, rather than the cutting velocity, is usually the factor that impacts the cutting time most; other authors have chosen to use it as a constant, while changing the cutting velocity. On the contrary, the parameters characterizing the cutter's wear are expressed in respect to the length of the cutting trajectory in this study, and the feed speed is being changed along with the cutting velocity. In addition, the cutting time, when the critical wear phase of the cutter initiates is equivalent to 16 hours for both, when milling with a cutting velocity of 20.4 m s^{-1} and 40 m s^{-1} . Therefore, the results of studies carried out by other authors should be similar, knowing that by increasing the speed, also the distance travelled in one unit of time increases. For example, if the cutting velocity increases twice and the feed speed remains the same, the cutter comes into contact with the wood

twice as much in the same unit of time, chipping off twice as much wood, and as a result, it is subjected to a higher level of friction. Consequently, the length value of the cutting trajectory will be twice as long at the same cutting time as it can be observable in this study. Another study indicates that by increasing the cutting velocity, the feed per tooth decreases, and therefore also decreases the amount of wood chipped off, which all results in an increase of the cutting power because a higher cutting resistance is created (Barcik et al., 2008). Furthermore, it has been ascertained that the resistance of wood, along with the cutting power, increases more when the cutting velocity is increased from 45 to 60 m s^{-1} , comparing to the observation of velocity increase from 30 to 45 m s^{-1} . The increase in the cutting resistance might be the cause for a more intense abrasion of the cutter, when the cutting velocity is higher. However, the increase in the cutting power might not be characterizing the wear of the cutter unequivocally, but unfortunately such a possibility has not been considered. Besides, the feed per tooth and the thickness of the chippings has not reduced in the aforesaid study. The above mentioned indicates that it may not be concluded that the results acquired in this study are contradictory, comparing to those of other authors, because a difference exists in the interpretation of the results and the parameters of the cutting mode used. However, a further research is necessary to clarify the impact of the cutting velocity in respect to the wear of the cutter.

Conclusions

1. The developed methodology can be used to analyze regularities of the wood cutting processes and for further knowledge obtaining. It is appropriate both sawing with circular saws and milling with cutterheads not only wood of soft deciduous but also wood of hard deciduous and coniferous trees cutting, because the developed methodology is more universal when compared with previously used.
2. The initial wear period is in the range of cutting trajectory up to 8,000 m but the beginning of the critical wear period is observed after reaching length of the cutting trajectory 95,000 m that corresponds to the cutting time of 16 hours.
3. Cutting velocity is significantly affecting the start of the critical wear period of the cutter and in further investigations, it is necessary to evaluate influence of cutting velocity on wear of the cutter, too.

References

1. Astakhov V.P., Davim J.P. (2008) Tools (geometry and material) and tool wear. In: Davim J.P. (eds) *Machining. Fundamentals and Recent Advances*, Springer, London, pp. 29-57.

2. Ābele A. (2010) Mīksto lapkoku griešanas procesu pētījumi: diplomdarbs (Studies of cutting process of hardwoods: diploma paper). LLU Kokapstrādes katedra, Jelgava, 2010, 56 lpp. (in Latvian).
3. Ābele A., Miončinskis U. (2012) Parameter changes characterizing the wear of the cutting tool in the milling process of aspen wood. *ProLigno*, 8(3), pp. 74-88.
4. Banshoya K., Nagatomi K., Murase Y. (1998) Relationship Between Cutting-Edge Hardness and Tool Life for Alloy-Steel Bit in Machine Boring of MDF. *Bulletin of the Faculty of School Education, Hiroshima University*, 20, pp. 179-189.
5. Barčík Š., Kminiak R., Řehák T., Kvietková M. (2010) The influence of selected factors on energy requirements for plain milling of beech wood. *Journal of Forest Science*, 56(5), pp. 243-250.
6. Barčík Š., Pivolusková E., Kminiak R. (2008) Effect of technological parameters and wood properties on cutting power in plane milling of juvenile poplar wood. *Drvna industrija*, 59(3), pp. 107-112.
7. Budakçı M., İlçe A.C., Korkut D.S., Gürleyen T. (2011) Evaluating the surface roughness of heat-treated wood cut with different circular saws. *BioResources*, 6(4), pp. 4247-4258.
8. Flitney R. (2007) *Seals and Sealing Handbook. Fifth edition*. Butterworth-Heinemann, Elsevier, Oxford, 620 p.
9. Fotin A., Cismaru I., Cismaru M., Salcá E-A. (2010) Study concerning the influence of milling parameters upon the surface quality. *ProLigno*, 6(1), pp. 55-65.
10. Fotin A., Cismaru I., Salcá E-A., Cismaru M. (2009) Influence of the variable parameters of the machining regimes upon the surface quality obtained by straight milling. *ProLigno*, 5(4), pp. 53-63.
11. Kováč J., Mikleš M. (2010) Research on individual parameters for cutting power of woodcutting process by circular saws. *Journal of Forest Science*, 56(6), pp. 271-277.
12. Nordström J. (2005) On wear of wood-cutting tools: Doctoral thesis. Karlstad University, Sweden, 2005, 56 p.
13. Nordström J., Bergström J. (2001) Wear testing of saw teeth in timber cutting. *Wear*, 250(1-12), pp. 19-27.
14. Ratnasingam J., Perkins M.C. (1998) An investigation into the tool wearing characteristics of rubberwood (*Hevea brasiliensis*) laminated veneer lumber. *Holz als Roh- und Werkstoff*, 56(1), pp. 31-35.
15. Simonin G., Meausoone P-J., Rougie A., Triboulot P. (2009) Carbide characterization for spruce rip-sawing. *ProLigno*, 5(2), pp. 49-57.
16. Sleņģis M.E., Miončinskis U., Dekšnis A. (2009) Apses un baltalkšņa koksnes frēzēšanas procesa pētījumi (Studies of milling process of aspen and grey alder wood). In: Andersons B., Daugavietis M., Tuherm H., Viesturs U., Grīnfelds A. (eds) *Lapu koku audzēšanas un racionālas izmantošanas pamatojums, jauni produkti un tehnoloģijas. Valsts pētījumu programma, 2005 – 2009: rakstu krājums (Substantiation of deciduous trees cultivation and rational utilisation, new products and technologies. State Research Programme, 2005 – 2009: Proceedings)*. Latvijas Valsts koksnes ķīmijas institūts, SIA Tipogrāfija Pērse, Rīga, 90-94. lpp. (in Latvian).